

HARDNESS

REFERENCE BLOCKS

& INDENTERS

ISO/IEC 17025 CERTIFIED REFERENCE TOOLS FOR HARDNESS TESTERS



CATALOGUE 2024

INTRODUCTION

UPI Laboratories Europe BV, ISO/IEC 17025 RvA accredited laboratory providing DIN EN ISO / ASTM dual certified test blocks and indenters.

The RvA, like UKAS, DAkkS, COFRAC, NVLAP, A2LA are ILAC (International Laboratory Accreditation Cooperation) members. Certificates issued by INNOVATEST Europe for test blocks and indenters meet or exceed the relevant ISO/ASTM requirements for hardness testing and comply with the requirements for NADCAP accredited/certified organizations.

Hardness test blocks or hardness reference plates are comparison plates most commonly made of Steel or Aluminum but could also be made of Brass or customer materials. They are used for the day to day Indirect Verification and Calibration of hardness testing machines and instruments. There are hardness test blocks for almost all hardness testing methods and scales.

Calibrating the display reading of a hardness tester against ISO/ASTM certified hardness test block values part of a normal quality assurance process. Adjusting your hardness tester according to the value engraved in a hardness test block, as long as the adjustments are minor, can be done after assurance that a correct and undamaged indenter/penetrator is installed and the tester operates normally. Indenters are available for almost all scales with viability of micro and macro diamond indenters and carbide or available in the different sizes by the different methods.

ISO & ASTM HARDNESS TEST BLOCKS and INDENTERS (RvA)

Hardness test blocks INNOVATEST Europe BV branded are manufactured according to standards ISO (International) and ASTM (American).

Such standards apply to the physical requirements as well to the method & the way the final value is found and confirmed." INNOVATEST Europe BV hardness test blocks and indenters are of excellent finish and have very low variation, excellent repeatability.

RAW MATERIALS USED

In order to manufacture good hardness test blocks, strict control over the quality of raw materials (Steel, Brass, Aluminum) is required. The entire block material needs to be homogenous, to assure low spread of readings and excellent repeatability. INNOVATEST Europe BV performs supplier audits to assure this.

HEAT TREATMENT

Distribution of the blocks in the hardening furnaces is of utmost importance, time, temperature and quench are all carefully controlled processes, to assure a top class product. INNOVATEST Europe BV performs supplier audits to assure this.

FINISHING

The next step in the process to ensure high quality 'blanks' is the grinding, polishing and lapping of the block surfaces. Any concerns on the surface quality are eliminated due to thorough selection after inspection. INNOVATEST performs supplier audits to assure this.

QUALITY CONTROL

Before proceeding with the ultimate calibration and engraving of the block hardness, blocks are undergoing a full inspection to ensure that they meet the physical requirements of ISO and ASTM (thickness, flatness, parallelism, surface roughness, magnetism and uniformity).

© INNOVATEST Europe BV

Changes in products and/or product specifications can emerge due to new technologies and/or continuous development.

We reserve the right to change or modify specifications of products without prior notice.

We recommend you to contact our sales office for up-to-date information.

© All rights reserved
C24CAT/02/EN

INNOVATEST[®]

TRACEABILITY

INNOVATEST hardness calibration blocks and indenters are calibrated & DUAL-certified by UPI Laboratories Europe BV traceable to National/ International standards according to ISO 6506, ISO 6507, ISO 6508, ISO 4545, ASTM E18, ASTM E92 and ASTM E10.



TEST BLOCKS

ROCKWELL REFERENCE BLOCKS

ROCKWELL DIAMOND SCALES

INNOVATEST Rockwell cone hardness calibration blocks are calibrated & DUAL-certified by UPI Laboratories Europe BV traceable to National/International standards according to ISO 6508/3 & ASTM-E18 A4.



ROCKWELL CARBIDE BALL SCALES

INNOVATEST Rockwell ball hardness calibration blocks are calibrated & DUAL-certified by UPI Laboratories traceable to National/International standards according to ISO 6508/3 & ASTM-E18 A4.

ROUND (dia. 60mm X 10mm thickness)

All mentioned hardness values are nominal, the actual calibrated values may vary.

ITEM NO.	DESCRIPTION											
HRC	20	25	30	35	40	45	50	55	60	63	65	67
HRA Soft	22	26	31	35	40	45	47	50	53	55	59	62
HRA Hard	60	63	65	68	70	73	76	78	81	83	84	85
HRD		44	48	51	55	59	63	67	71	75		
HR15N		71	74	76	79	82	85	88	90	92		
HR30N		46	50	55	59	64	68	72	77	81		
HR45N		25	31	37	43	49	55	60	66	72		

Deviating scales or hardness can be ordered by customer request.
Blocks can be supplied with NADCAP compliant grid.

ROUND (dia. 60mm X 10mm thickness)

All mentioned hardness values are nominal, the actual calibrated values may vary.

ITEM NO.	DESCRIPTION												
HRB	10	20	30	40	50	60	65	70	75	80	85	90	95
HRE (alu)			75	81	87	93	100						
HRF (alu)**			74	80	86	91	97						
HRM*	85	110											
HRR*	105			125									
HR15T			70	73	77	80	83	85	86	88	90	91	
HR30T			36	43	49	56	63	66	69	73	76	80	
HR45T				12	22	32	43	48	53	58	63	68	

Deviating scales or hardness can be ordered by customer request.
Blocks can be supplied with NADCAP compliant grid.

* The scales of the 1/4" and 1/2" ball indenter are only ASTM E18, not ISO 6508.

** Scales are outside the scope of accreditation.

TEST BLOCKS RANGE

25 MM BLOCK



60 MM BLOCK



65 MM BLOCK



90 MM BLOCK



VICKERS REFERENCE BLOCKS

MACRO VICKERS SCALES

INNOVATEST Macro Vickers hardness calibration blocks are calibrated & DUAL-certified by UPI Laboratories Europe BV traceable to National/International standards according to ISO 6507/3 & ASTM-E92 A4.



ROUND (dia. 60mm X 10mm thickness)

All mentioned hardness values are nominal, the actual calibrated values may vary.

ITEM NO.	DESCRIPTION																
HV0.1	40	70	100	150	200	250	300	350	400	450	500*	550*	600*	650*	700*	750*	800*
HV0.2	40	70	100	150	200	250	300	350	400	450	500	550	600	650	700	750	800
HV0.3	40	70	100	150	200	250	300	350	400	450	500	550	600	650	700	750	800
HV0.5	40	70	100	150	200	250	300	350	400	450	500	550	600	650	700	750	800
HV1	40	70	100	150	200	250	300	350	400	450	500	550	600	650	700	750	800
HV2	40	70	100	150	200	250	300	350	400	450	500	550	600	650	700	750	800
HV3	40	70	100	150	200	250	300	350	400	450	500	550	600	650	700	750	800
HV5	40	70	100	150	200	250	300	350	400	450	500	550	600	650	700	750	800
HV10	40	70	100	150	200	250	300	350	400	450	500	550	600	650	700	750	800
HV20	40	70	100	150	200	250	300	350	400	450	500	550	600	650	700	750	800
HV30	40	70	100	150	200	250	300	350	400	450	500	550	600	650	700	750	800
HV50	40*	70	100	150	200	250	300	350	400	450	500	550	600	650	700	750	800
HV100	40*	70*	100	150	200	250	300	350	400	450	500	550	600	650	700	750	800

* Hardness value is outside the scope of the ISO/ASTM standards due to indentations smaller than 0,020mm. Deviating scales or hardness can be ordered by customer request.



VICKERS REFERENCE BLOCKS

MICRO VICKERS SCALES

INNOVATEST Micro Vickers hardness calibration blocks are calibrated & DUAL-certified by UPI Laboratories Europe BV traceable to National/International standards according to ISO 6507/3 & ASTM-E92 A4.



ROUND (dia. 25mm X 6mm thickness)

All mentioned hardness values are nominal, the actual calibrated values may vary.

ITEM NO.	DESCRIPTION																
HMV2	40	70	100	150	200	250	300	350	400	450	500	550	600	650	700	750	800
HMV1	40	70	100	150	200	250	300	350	400	450	500	550	600	650	700	750	800
HMV0.5	40	70	100	150	200	250	300	350	400	450	500	550	600	650	700	750	800
HMV0.3	40	70	100	150	200	250	300	350	400	450	500	550	600	650	700	750	800
HMV0.2	40	70	100	150	200	250	300	350	400	450	500	550	600	650	700	750	800
HMV0.1	40	70	100	150	200	250	300	350	400	450	500*	550*	600*	650*	700*	750*	800*
HMV0.05	40	70	100	150	200	250*	300*	350*	400*	450*	500*	550*	600*	650*	700*	750*	800*
HMV0.025	40	70	100	150*	200*	250*	300*	350*	400*	450*	500*	550*	600*	650*	700*	750*	800*
HMV0.02	40	70	100*	150*	200*	250*	300*	350*	400*	450*	500*	550*	600*	650*	700*	750*	800*
HMV0.015	40	70	100*	150*	200*	250*	300*	350*	400*	450*	500*	550*	600*	650*	700*	750*	800*
HMV0.010	40	70*	100*	150*	200*	250*	300*	350*	400*	450*	500*	550*	600*	650*	700*	750*	800*

* Hardness value is outside the scope of the ISO/ASTM standards due to indentations smaller than 0,020mm. Deviating scales or hardness can be ordered by customer request.



KNOOP REFERENCE BLOCKS

BRINELL REFERENCE BLOCKS

KNOOP SCALES

INNOVATEST Knoop hardness calibration blocks are calibrated & DUAL-certified by UPI Laboratories Europe BV traceable to National/International standards according to ISO 4545/3 & ASTM-E92 A4.



BRINELL SCALES

INNOVATEST Brinell hardness calibration blocks are calibrated & DUAL-certified by UPI Laboratories Europe BV traceable to National/International standards according to ISO 6506/3 & ASTM-E10 A4.



ROUND (dia. 25mm X 6mm thickness)

All mentioned hardness values are nominal, the actual calibrated values may vary.

ITEM NO.	DESCRIPTION																
HK0.01**	40**	70**	100**	150**	200**	250**	300**	350**	400*	450*	500*	550*	600*	650*	700*	750*	800*
HK0.015**	40**	70**	100**	150**	200**	250**	300**	350**	400**	450**	500**	550*	600*	650*	700*	750*	800*
HK0.02**	40**	70**	100**	150**	200**	250**	300**	350**	400**	450**	500**	550**	600**	650**	700**	750*	800*
HK0.025**	40**	70**	100**	150**	200**	250**	300**	350**	400**	450**	500**	550**	600**	650**	700**	750**	800**
HK0.05**	40**	70**	100**	150**	200**	250**	300**	350**	400**	450**	500**	550**	600**	650**	700**	750**	800**
HK0.1	40**	70	100	150	200	250	300	350	400	450	500	550	600	650	700	750	800
HK0.2	40**	70**	100	150	200	250	300	350	400	450	500	550	600	650	700	750	800
HK0.3	40**	70**	100**	150	200	250	300	350	400	450	500	550	600	650	700	750	800
HK0.5	40**	70**	100**	150**	200	250	300	350	400	450	500	550	600	650	700	750	800
HK1	40**	70**	100**	150**	200**	250**	300**	350	400	450	500	550	600	650	700	750	800
HK2	40**	70**	100**	150**	200**	250**	300**	350**	400**	450**	500**	550**	600**	650**	700**	750	800

Deviating scales or hardness can be ordered by customer request.

* Hardness value is outside the scope of the ISO/ASTM standards due to indentations smaller than 0,020mm

** Scales are outside the scope of accreditation.

CONVENIENT PACKAGING



ROUND (dia. 90mm X 16mm thickness)

All mentioned hardness values are nominal, the actual calibrated values may vary.

ITEM NO.	DESCRIPTION															
HBW 10/3000	70*	100	150	170	200	250	300	350	400	450	500	550	600	650		
HBW 10/1500	70	100	150	170	200	250	300	350*	400*	450*	500*	550*	600*	650*		
HBW 10/1000	70	100	150	170	200	250*	300*	350*	400*	450*	500*	550*	600*	650*		
HBW 10/500	40	70	100	150*	170*	200*	250*	300*	350*	400*	450*	500*	550*	600*	650*	
HBW 5/750	70*	100	150	170	200	250	300	350	400	450	500	550	600	650		
HBW 5/250	70	100	150	170	200	250*	300*	350*	400*	450*	500*	550*	600*	650*		
HBW 5/125	40	70	100	150*	170*	200*	250*	300*	350*	400*	450*	500*	550*	600*	650*	

Deviating scales or hardness can be ordered by customer request.
Blocks can be supplied with NADCAP compliant grid.

* Hardness value is outside the scope of the ISO/ASTM standards

ROUND (dia. 60mm X 10mm thickness)

All mentioned hardness values are nominal, the actual calibrated values may vary.

ITEM NO.	DESCRIPTION															
HBW 2.5/187.5	40*	70*	100	150	170	200	250	300	350	400	450	500	550	600	650	
HBW 2.5/62.5	40	70	100	150	170	200	250*	300*	350*	400*	450*	500*	550*	600*	650*	
HBW 2.5/31.25	40	70	100	150*	170*	200*	250*	300*	350*	400*	450*	500*	550*	600*	650*	
HBW 1/30	40*	70*	100	150	170	200	250	300	350	400	450	500	550	600	650	
HBW 1/10	40	70	100	150	170	200	250*	300*	350*	400*	450*	500*	550*	600*	650*	
HBW 1/5	40	70	100	150*	170*	200*	250*	300*	350*	400*	450*	500*	550*	600*	650*	

Deviating scales or hardness can be ordered by customer request.
Blocks can be supplied with NADCAP compliant grid.

* Hardness value is outside the scope of the ISO/ASTM standards

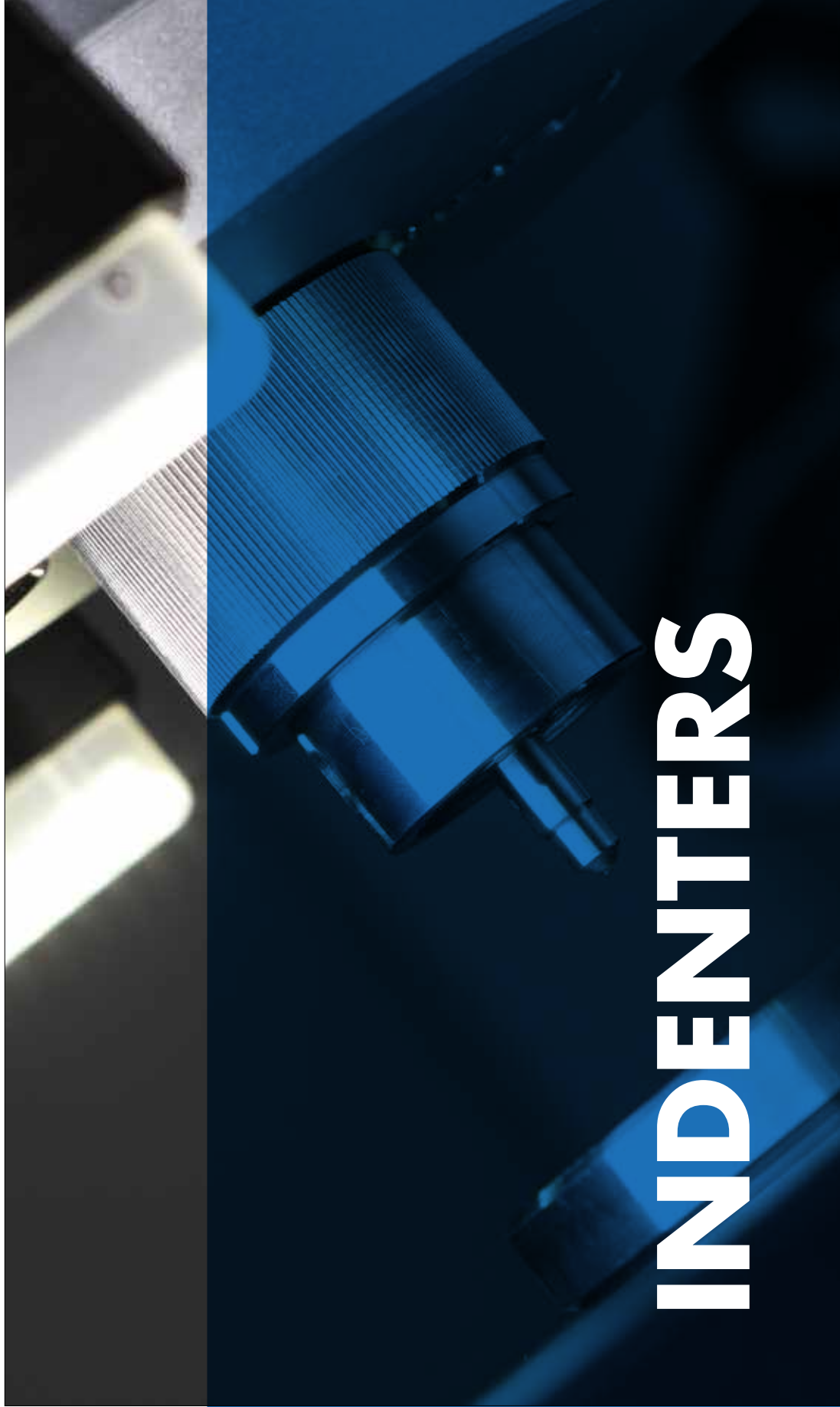

INDENTERS

ROCKWELL INDENTERS

ROCKWELL DIAMOND & BALL INDENTERS

INNOVATEST Rockwell Indenters are calibrated & DUAL-certified by UPI Laboratories Europe BV traceable to National/International standards according to ISO 6508/2 & ASTM-E18 A3.



ITEM NO.		DESCRIPTION
UPI/6003		Rockwell diamond indenter $\varnothing 3\text{mm}$, acc. to ISO 6508/2 & ASTM-E18 A3
UPI/6004		Rockwell diamond indenter $\varnothing 3\text{mm}$, L=12mm, acc. to ISO 6508/2 & ASTM-E18 A3
UPI/6005		Rockwell diamond indenter $\varnothing 6.35\text{mm}$, acc. to ISO 6508/2 & ASTM-E18 A3
UPI/7503		1/16" Embedded carbide ball indenter $\varnothing 3\text{mm}$, with 1 ball, acc. to ISO 6508/2 & ASTM-E18 A3
UPI/7603		1/8" Embedded carbide ball indenter $\varnothing 3\text{mm}$, with 1 ball, acc. to ISO 6508/2 & ASTM-E18 A3
UPI/7703		1/4" Embedded carbide ball indenter $\varnothing 3\text{mm}$, with 1 ball, acc. to ASTM-E18 A3
UPI/7506		1/16" Carbide ball indenter $\varnothing 6.35\text{mm}$, with 1 ball, acc. to ISO 6508/2 & ASTM-E18 A3
UPI/7606		1/8" Carbide ball indenter $\varnothing 6.35\text{mm}$, with 1 ball, acc. to ISO 6508/2 & ASTM-E18 A3
UPI/7706		1/4" Carbide ball indenter $\varnothing 6.35\text{mm}$, with 1 ball, acc. to ASTM-E18 A3
UPI/7806		1/2" Carbide ball indenter $\varnothing 6.35\text{mm}$, with 1 ball, acc. to ASTM-E18 A3
UPI/7808		1/2" Embedded carbide ball indenter $\varnothing 3\text{mm}$, with 1 ball, acc. to ASTM-E18 A3
UPI/2507		1/16" Carbide ball, for Rockwell ball indenter, acc. to ISO 6508/2 & ASTM-E18 A3
UPI/2509		1/8" Carbide ball, for Rockwell ball indenter, acc. to ISO 6508/2 & ASTM-E18 A3
UPI/2514		1/4" Carbide ball, for Rockwell ball indenter, acc. to ASTM-E18 A3
UPI/2519		1/2" Carbide ball, for Rockwell ball indenter, acc. to ASTM-E18 A3

VICKERS & KNOOP INDENTERS

BRINELL INDENTERS



MACRO & MICRO VICKERS INDENTERS



INNOVATEST (Micro) Vickers Indenters are calibrated & DUAL-certified by UPI Laboratories Europe traceable to National/International standards according to ISO 6507/2 & ASTM-E92 A3.

KNOOP INDENTERS

INNOVATEST Knoop Indenters are calibrated & DUAL-certified by UPI Laboratories Europe traceable to National/International standards according to ISO 4545/2 & ASTM-E92 A3.



ITEM NO.		DESCRIPTION
UPI/8010		Vickers indenter ø6.35mm, acc. to ISO 6507/2 & ASTM-E92 A3
UPI/8105		Vickers indenter ø3mm, acc. to ISO 6507/2 & ASTM-E92 A3











ITEM NO.		DESCRIPTION
UPI/8205		Knoop indenter ø3mm, acc. to ISO 4545/2 & ASTM-E92 A3
UPI/8220		Knoop indenter ø6.35mm, acc. to ISO 4545/2 & ASTM-E92 A3
UPI/8221		Knoop indenter ø6.35mm, acc. to ISO 4545/2 & ASTM-E92 A3 Indenter is rotated 90°

∅ = shaft diameter for machine mounting.



BRINELL BALL INDENTERS

INNOVATEST Brinell Indenters are calibrated & DUAL-certified by UPI Laboratories Europe BV traceable to National/International standards according to ISO 6506/2 & ASTM-E10 A3.

ITEM NO.		DESCRIPTION
UPI/7001		1mm Embedded carbide ball indenter ø3mm, acc. to ISO 6506/2 & ASTM-E10 A3
UPI/7006		2.5mm Embedded carbide ball indenter ø3mm, acc. to ISO 6506/2 & ASTM-E10 A3
UPI/7011		5mm Embedded carbide ball indenter ø3mm, acc. to ISO 6506/2 & ASTM-E10 A3
UPI/7000		1mm Carbide ball indenter ø6.35mm, acc. to ISO 6506/2 & ASTM-E10 A3
UPI/7005		2.5mm Carbide ball indenter ø6.35mm, acc. to ISO 6506/2 & ASTM-E10 A3
UPI/7010		5mm Carbide ball indenter ø6.35mm, acc. to ISO 6506/2 & ASTM-E10 A3
UPI/7015		10mm Carbide ball indenter ø6.35mm, acc. to ISO 6506/2 & ASTM-E10 A3
UPI/2005		1.0mm Carbide ball, for ø6.35mm indenters, acc. to ISO 6506/2 & ASTM-E10 A3
UPI/2010		2.5mm Carbide ball, for ø6.35mm indenters, acc. to ISO 6506/2 & ASTM-E10 A3
UPI/2015		5.0mm Carbide ball, for ø6.35mm indenters, acc. to ISO 6506/2 & ASTM-E10 A3
UPI/2020		10.0mm Carbide ball, for ø6.35mm indenters, acc. to ISO 6506/2 & ASTM-E10 A3

RE-CALIBRATION COST (Examination and calibration of used indenters)

ITEM NO.		DESCRIPTION
UPI/9090		Rockwell C indenter
UPI/9190		Vickers indenter
UPI/9092		Micro Vickers indenter

All dimensions are in mm.

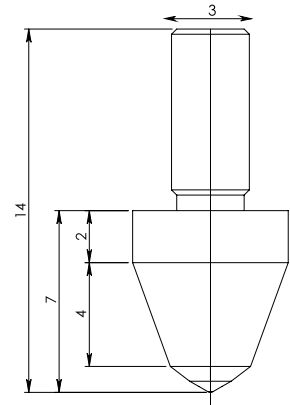

UPI/6003

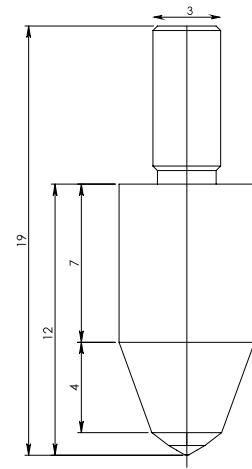

UPI/6004

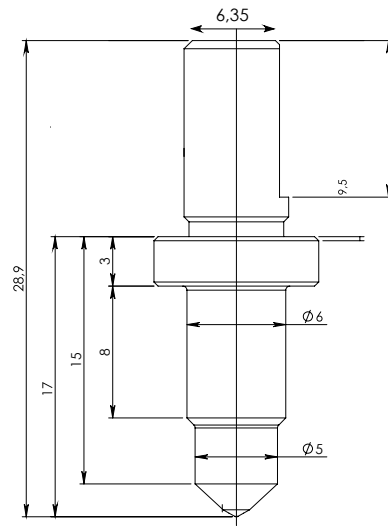

UPI/6005

All dimensions are in mm.

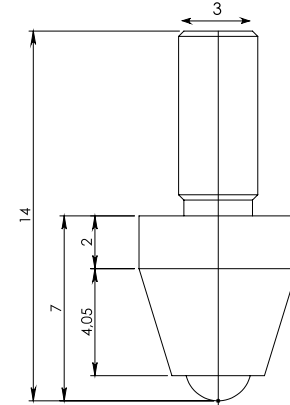

UPI/7001

UPI/7006

UPI/7011

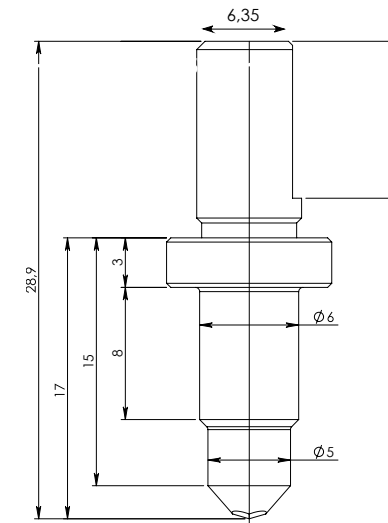

UPI/8010

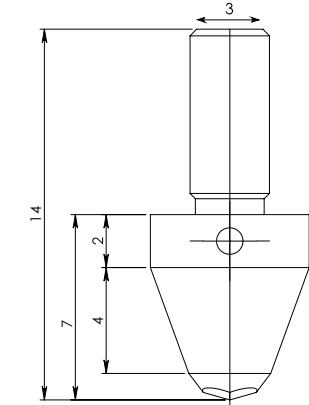

UPI/8105

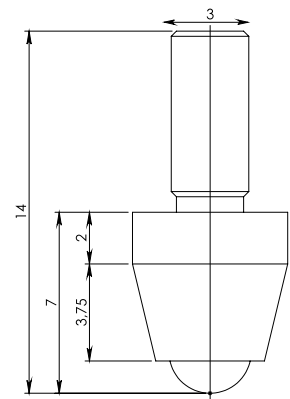

UPI/7503

UPI/7603

UPI/7703

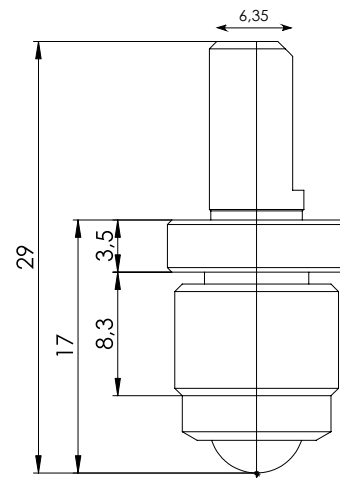

UPI/7506

UPI/7606

UPI/7706

UPI/7806

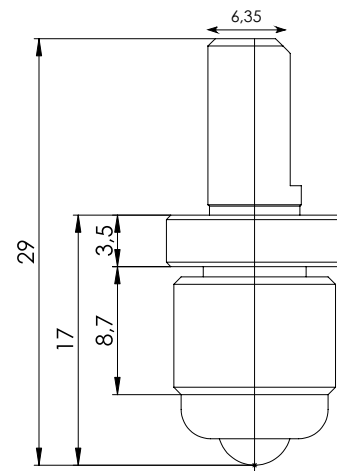

UPI/7005

UPI/7010

UPI/7015

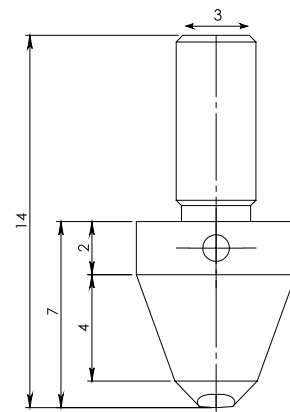

UPI/8205

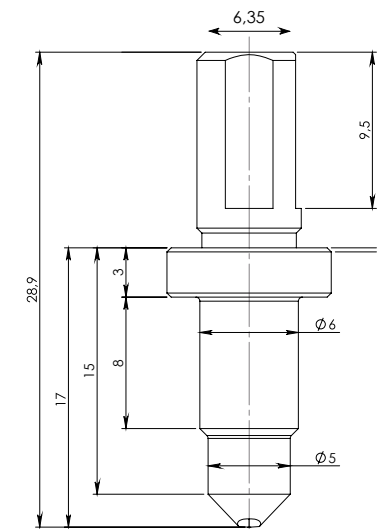

UPI/8221

EUROPE

INNOVATEST Deutschland GmbH.
Sales & Service
Phone: +49 245 670 59 500
info@innovatest-deutschland.com
www.innovatest-deutschland.com

INNOVATEST France SARL
Sales & Service
Phone: +33 1 848 88038
commercial@innovatest-france.com
www.innovatest-france.com

INNOVATEST UK Ltd.
Sales & Service
Phone: +44 (0) 121 824 4775
info@innovatest-uk.com
www.innovatest-uk.com

INNOVATEST Polska sp. z o.o
Sales & Service
Phone: +48 697 099 826
info@innovatest-polska.pl
www.innovatest-poland.com

MIDDLE EAST

INNOVATEST Middle East LLC
Sales & Service
Phone: +971- 4- 880 0875
info@innovatest-mideast.com
www.innovatest-mideast.com

NORTH-AMERICA

INNOVATEST USA Inc.
Sales & Service
Phone: +1 267 317 4300
info@innovatest-usa.com
www.innovatest-usa.com

ASIA

INNOVATEST Shanghai Co., Ltd.
Sales & Service
Phone: +86 21 60906200
Fax: +86 21 60912595
info@innovatest-shanghai.com
www.innovatest-shanghai.com

INNOVATEST Japan K.K.
Sales & Service
Phone: +81 3 6667 0554
Fax: +81 3 6667 0556
info@innovatest-japan.com
www.innovatest-japan.com

INNOVATEST South East Asia
Sales & Service
Phone: +65 6451 1123
Fax: +65 6452 1011
info@innovatest-singapore.com
www.innovatest-singapore.com

Distributor :

CORPORATE HEAD OFFICE

INNOVATEST Europe BV
Manufacturing, Distribution & Service
Borgharenweg 140
6222 AA MAASTRICHT
The Netherlands

Phone: +31 43 3520060
info@innovatest-europe.com
www.innovatest-europe.com